

ROTARY TILLERS UM-SERIES UM1.8 (UM72) – UM1.5(UM60)

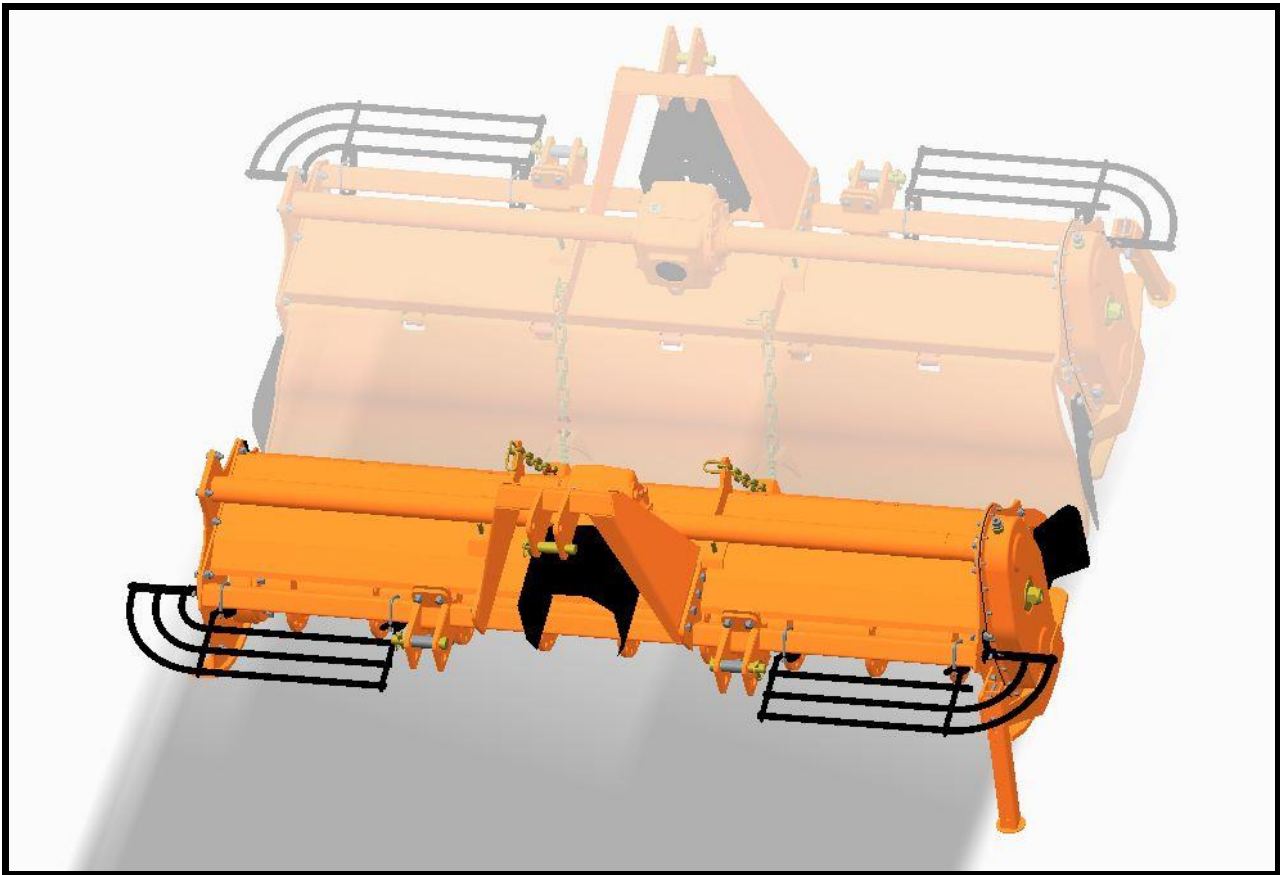

Assembly Instruction Manual



Tirth Agro Technology Pvt. Ltd.
ISO 9001:2008 & CE Certified Company



Manual P/N:

➤ **Top Mast Assembly :**

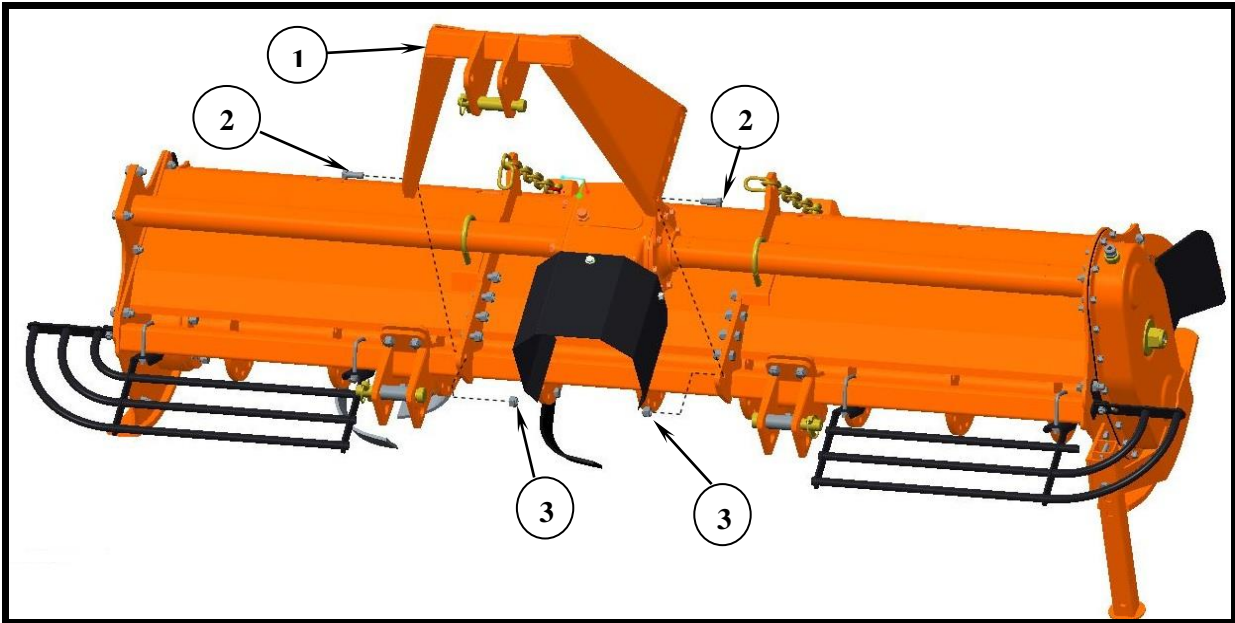

Sr. No	P/Number	Description
1	14087	TOP MAST COMP (U/M-SERIES)
2	10192	HEX BOLT M12 X 1.75 X 30
3	1209	NYLOCK NUT M12 X 1.75

➤ **Hitching Bracket Assembly :**

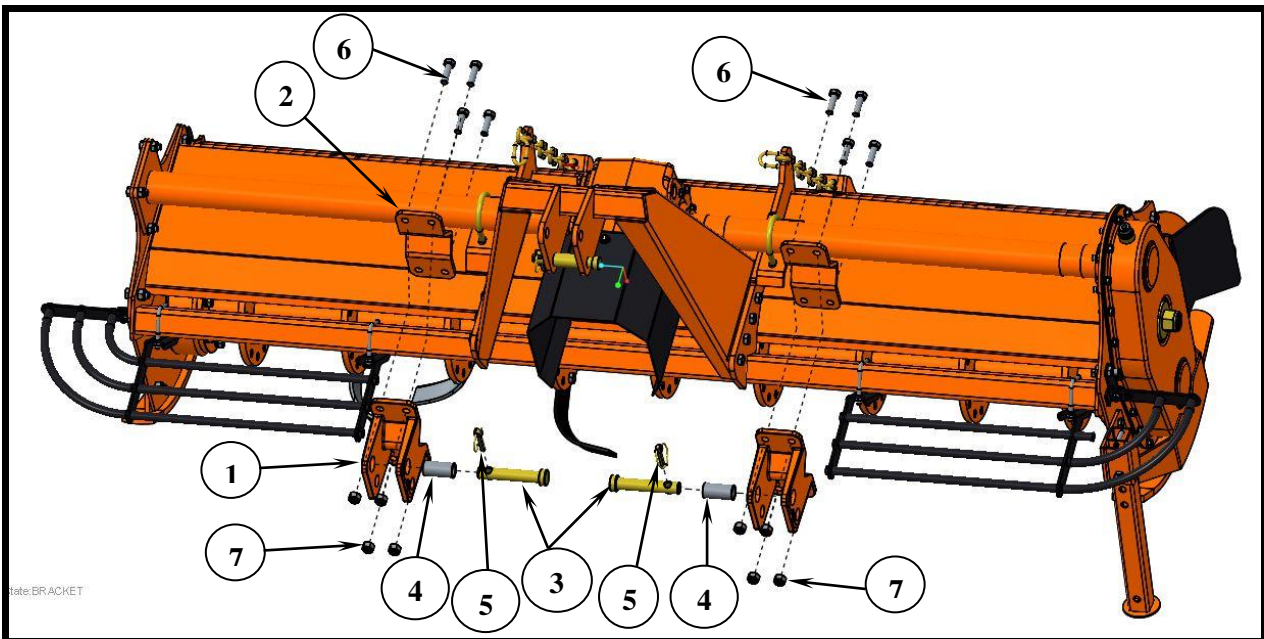

U-Series UM Rotary Tillers

Sr. No	P/Number	Description
1	4678	CASTING BRACKET (REG L)
2	1570	CASTING HITCHING BRACKET ANGLE (REG L)
3	1216	HITCH PIN BOTTOM CAT-I (DIA-22 X 129)
4	14093	BUSH (DIA. 28 X 22 X 56 L)
5	1218	LINCH PIN
6	10195	HEX BOLT M12 X 1.75 X 40
7	1209	NYLOCK NUT M12 X 1.75

➤ **Trailing Board Assembly :**

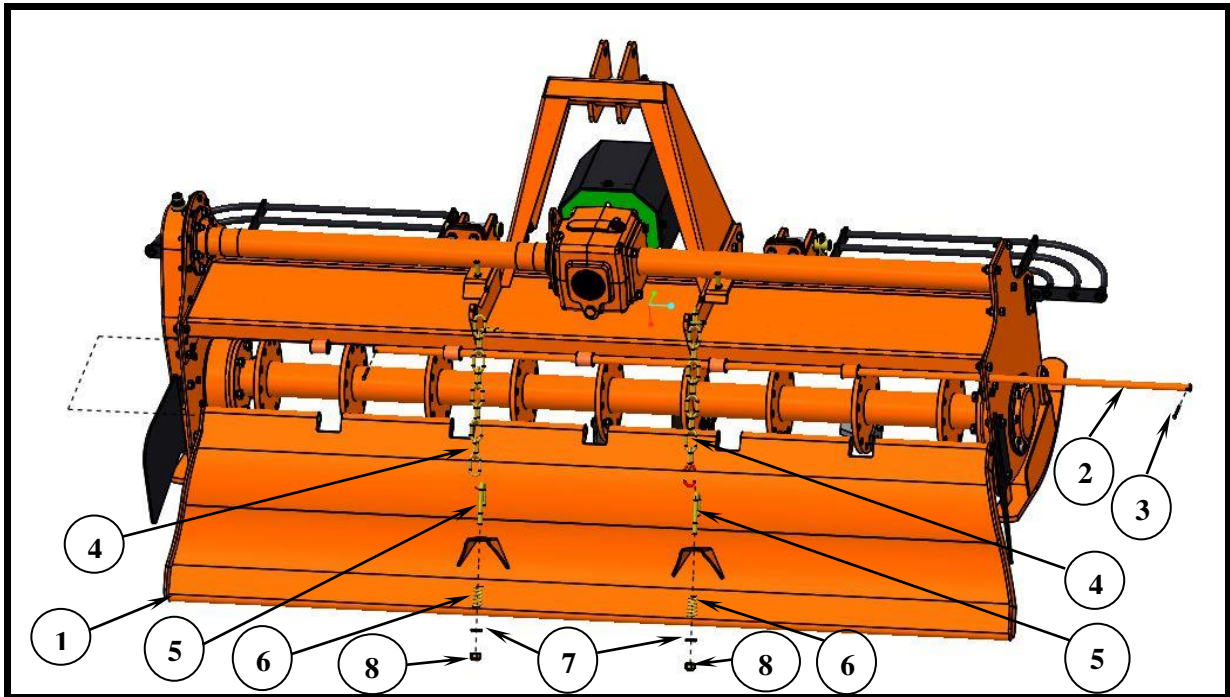

Sr. No	P/Number	Description
1	14089	TRAILING BOARD COMP 1.8M (U/M-SERIES)
2	14088	TRAILING BOARD ROD 1.8M(U/M-SERIES)
3	19018	COTTER PIN (DIA 4 X 35)
4	14073	LIFTING CHAIN TB
5	14004	J-BOLT M12 x 1.75 x 24 x 87.5 x 25TL
6	14005	U-BOLT SPRING (U-SERIES)
7	8126	PLAIN WASHER 12mm
8	1209	NYLOCK NUT M12 X 1.75

➤ **PTO Shaft Guard Assembly :**

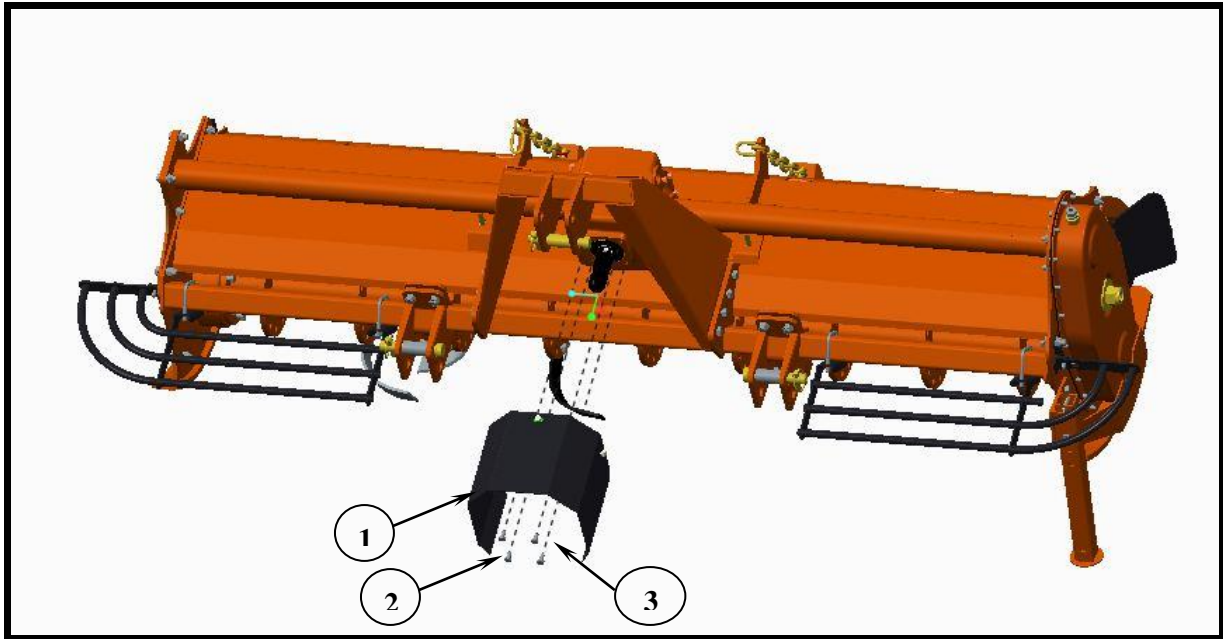

Sr. No	P/Number	Description
1	1547	PTO SHAFT GUARD ASSEMBLY
2	8190	HEX BOLT M8 X 1.25 X 15
3	8064	PLAIN WASHER 8mm

➤ Dip Stick Replacement :

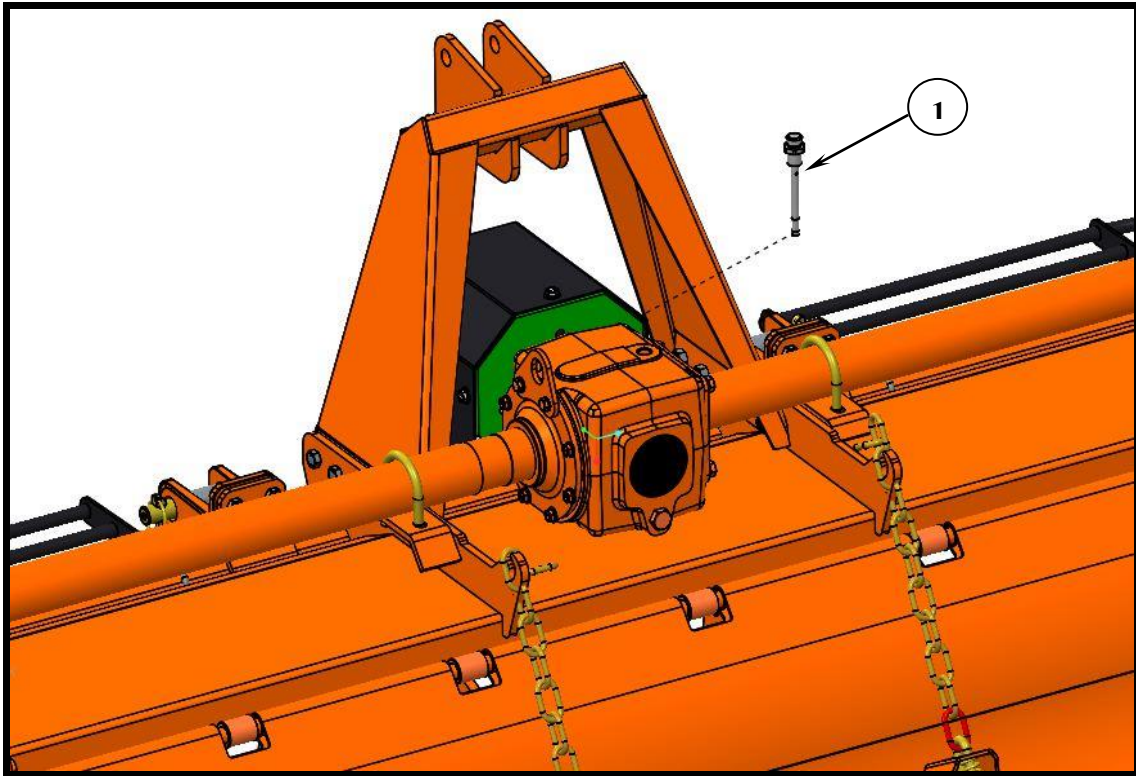

Sr. No	P/Number	Description
1	14237	DIPSTICK 85mm (M16 x 1.5)

➤ Air Breather Replacement :

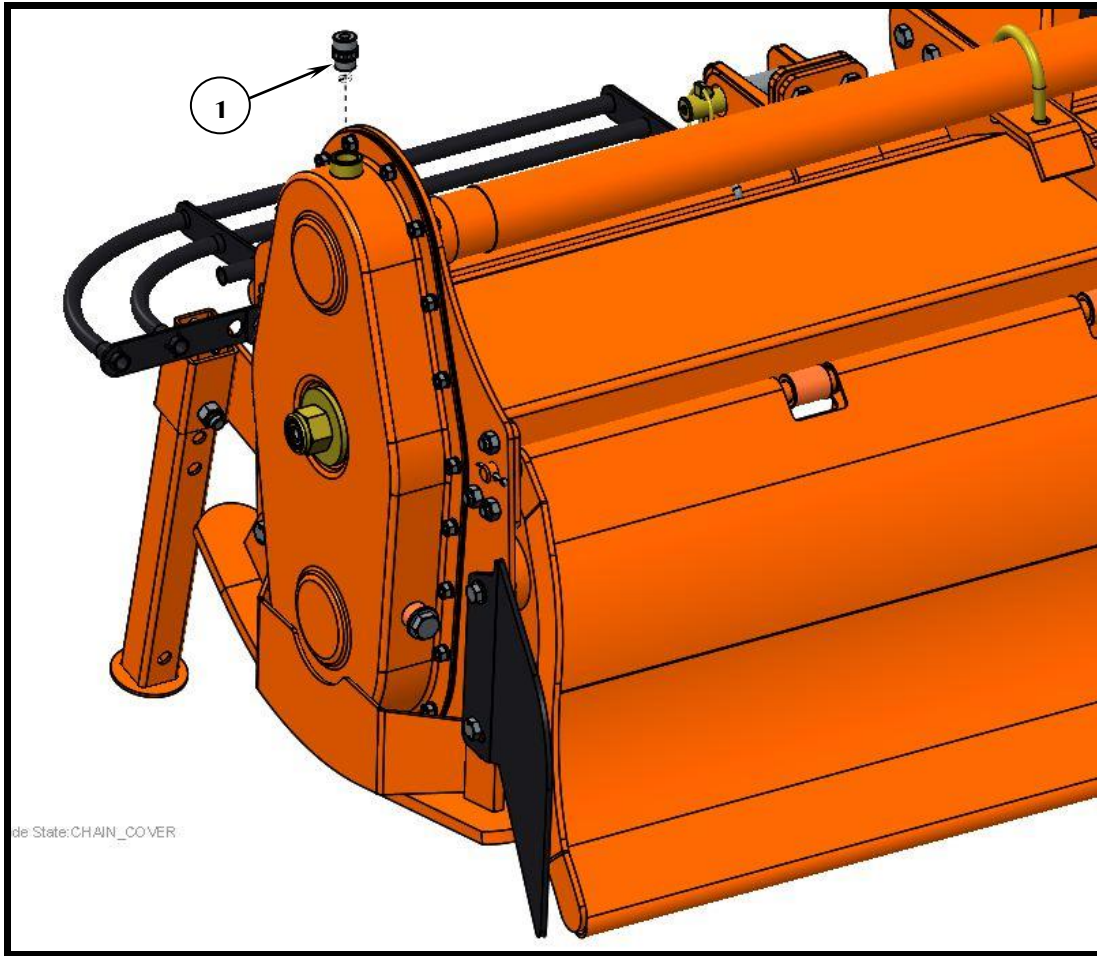

Sr. No	P/Number	Description
1	8231	AIR BREATHER 1/2" BSP

➤ **Depth Skid Assembly :**

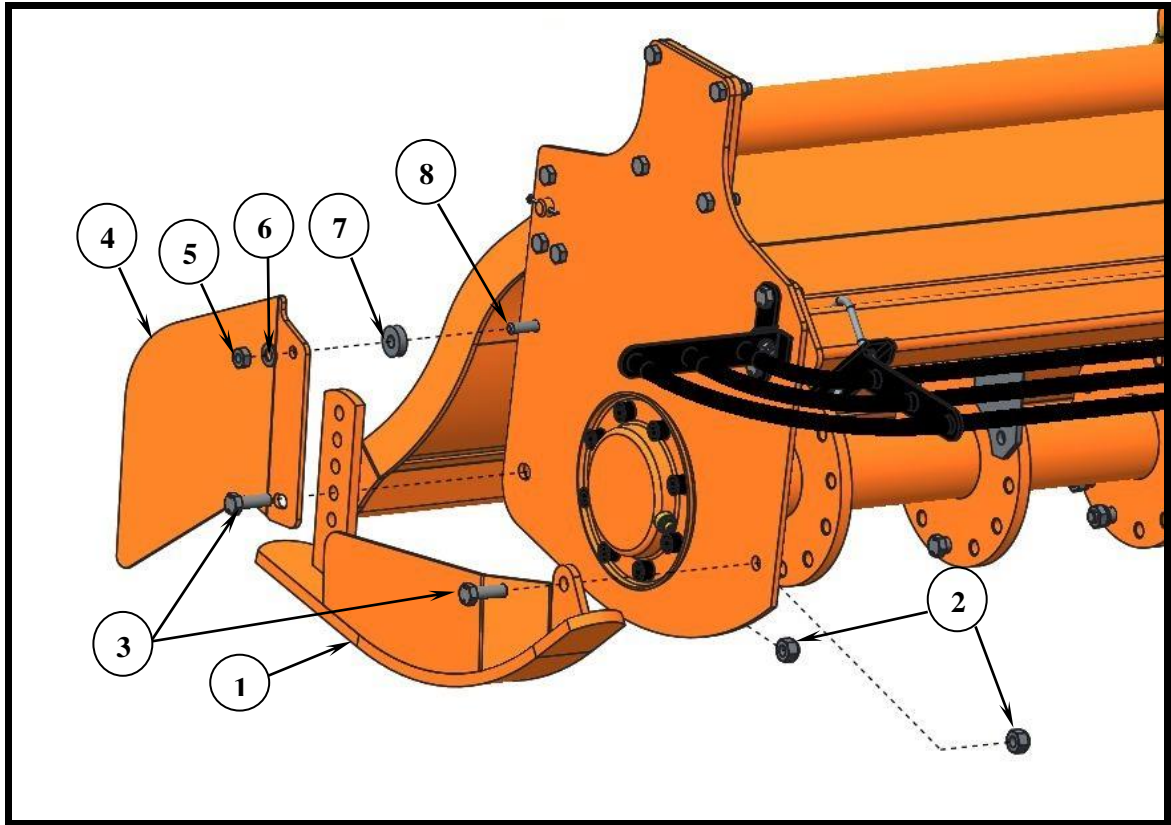

Sr. No	P/Number	Description
1	14010	DEPTH SKID COMP RH (U-SERIES)
2	1209	NYLOCK NUT M12 X 1.75
3	10192	HEX BOLT M12 X 1.75 X 30
4	1299	HEX NUT M10 X 1.50
5	8078	PLAIN WASHER 10mm
6	14194	SPACER DIA-28 x 11 x 8 MM
7	14183	TB GAURD PLATE LH (U-SERIES)
8	10181	HEX BOLT M10 X 1.50 X 30

➤ **CE KIT Assembly :**

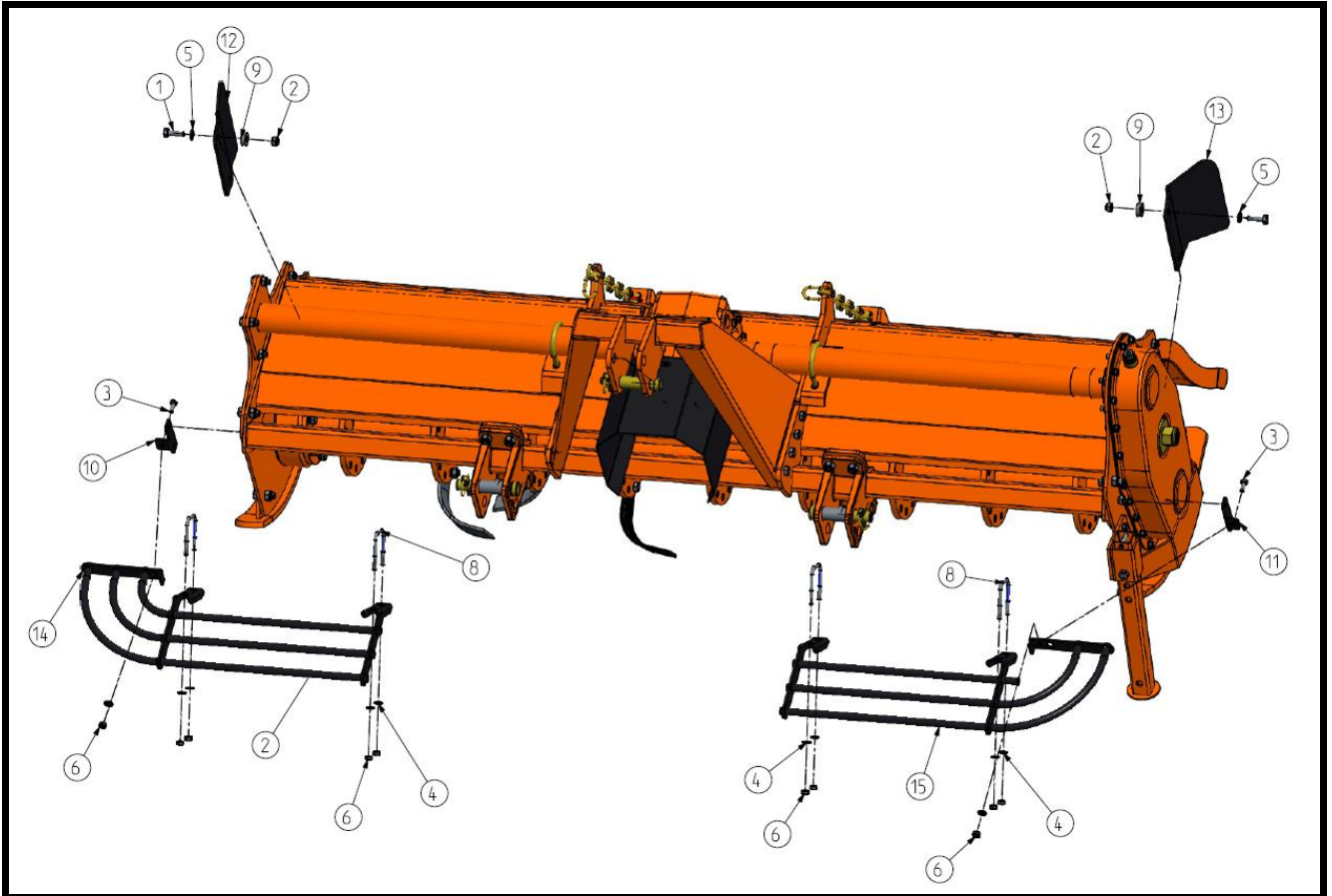

Sr No.	P/Number	PART NAME
1	6068	HEX BOLT M10 X 1.50 X 35
2	1298	NYLOCK NUT M10 X 1.50
3	8040	HEX BOLT M8 X 1.25 X 20
4	8064	PLAIN WASHER 8mm
5	8078	PLAIN WASHER 10mm
6	8181	HEX NUT M8 X 1.25
7	8190	HEX BOLT M8 X 1.25 X 15
8	14190	U-BOLT M8 X 1.25 X 77 X 60 X 28TL
9	14194	SPACER DIA-28 x 11 x 8 MM
10	14225	BARRIER ASM SUPPORT CLAMP LH (UM-SERIES)
11	14226	BARRIER ASM SUPPORT CLAMP RH (UM-SERIES)
12	14228	TB GAURD PLATE LH (UM-SERIES)
13	14229	TB GAURD PLATE RH (UM-SERIES)
14	14234	CE BARRIER COMP. SRT-1.8 LH (UM-SERIES)
15	14235	CE BARRIER COMP. SRT-1.8 RH (UM-SERIES)



Tirth Agro Technology Pvt. Ltd.
(An ISO 9001:2008 & CE Certified Company)

National Highway – 27, Nr. Bharudi Toll Plaza,
Gondal Road **At.:** Bhunava – 360311 **Ta.** Gondal,
Dist.: Rajkot. **State:** Gujarat- INDIA.

Phone: + 91 (2827) 661637

e-mail: info@shaktimanagro.com